

TOP VIEW

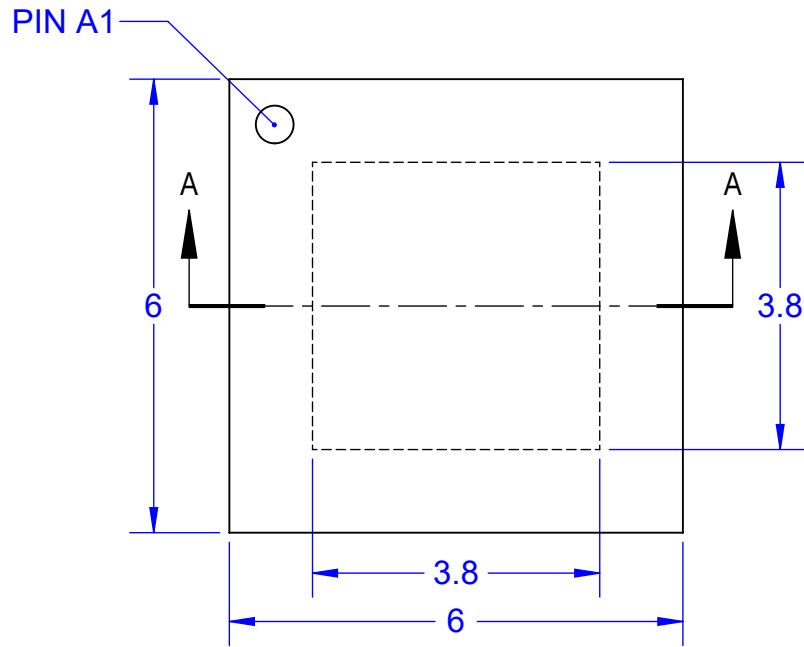

BALL VIEW

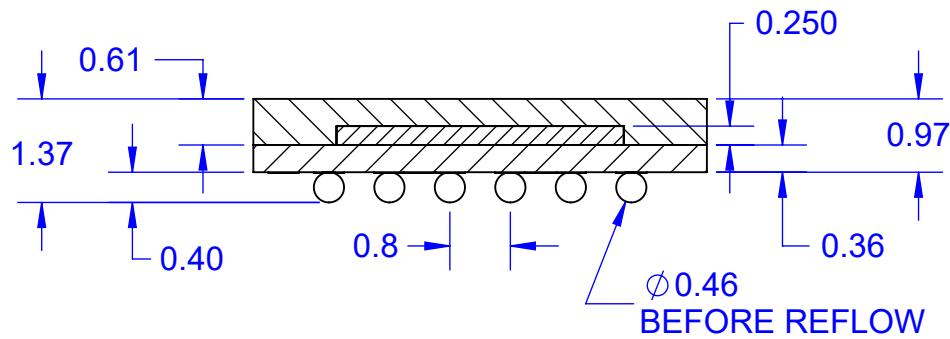
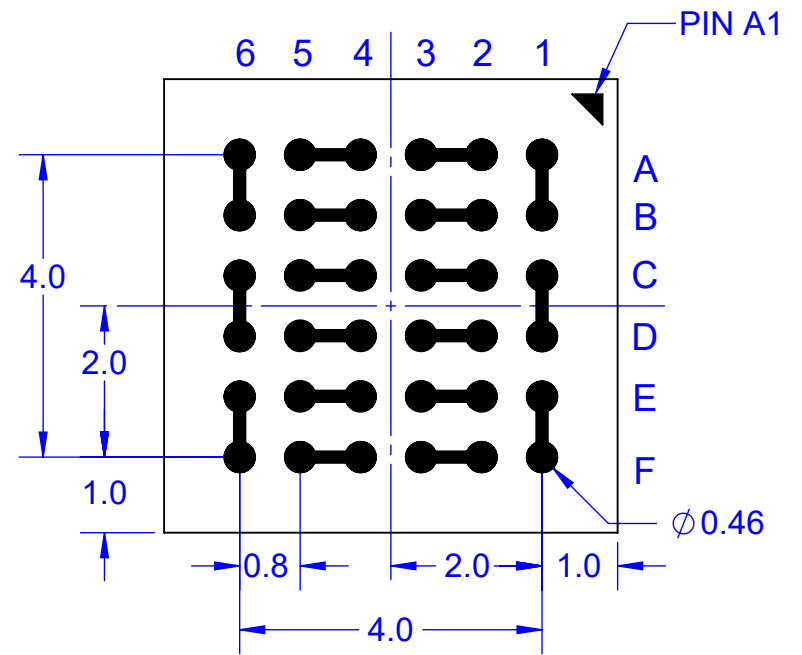

SECTION A-A

Notes: (Unless Otherwise Specified).

- 1) ALL DIMENSIONS ARE IN MM.
- 2) SOLDER BALL ALLOY: SEE PART NUMBER TABLE.
- 3) BALL DIAMETER (BEFORE REFLOW): 0.46mm.
- 4) SOLDER MASK DEFINED PAD OPENING: 0.40mm [15.7 MIL].
- 5) PAD Cu DIAMETER: 0.566mm [22 MIL].
- 6) SUBSTRATE MATERIAL: BT.
- 7) DUMMY DIE: 0.25mm [10 MIL] THICK.
- 8) DAISY CHAIN PATTERN (SEE PAGE 2).
- 9) MSL-3 RECOMMEND BAKING 24 HOURS @ 125C TO REMOVE MOISTURE PRIOR TO SOLDERING TO PC BOARD.

D5FH'BI A69F'H56 @				
D5FH'BI A69F	65 @ @5 @ @CM	DV! : F99	Fc < G	G] 8 9
BGA36T.8C-DC069D	Sn96.5/Ag3.0/Cu0.5	YES	YES	YES
BGA36T.8-DC069D	NONE	YES	YES	YES

APPROVALS	DATE	TopLine®			
DRAWN T. Au	4/30/2024	TITLE BGA36T.8-DC069D DAISY CHAIN DUMMY			
ENG M. Hart	4/30/2024				
MFG		SCALE	SIZE A	DRAWING NO. 580699	REV A
QA		DO NOT SCALE DRAWING		SHEET 1 OF 3	
CUST					
REVISED					

BALL VIEW

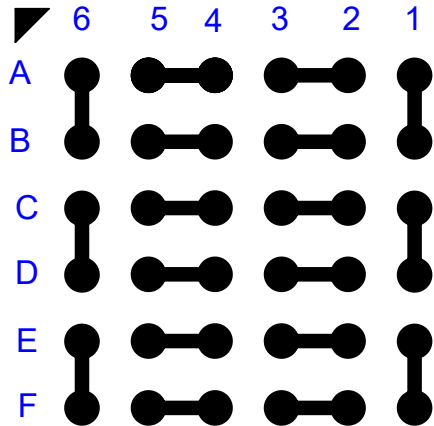

BOTTOM SIDE
(TOP X-RAY VIEW)

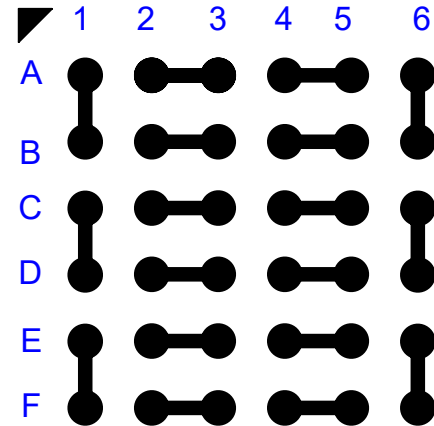

TOP VIEW

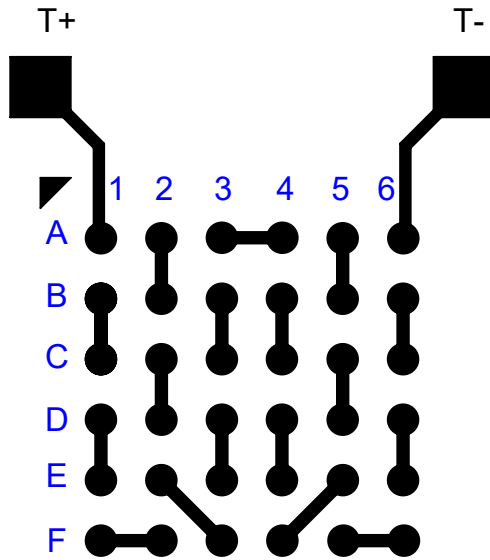

TEST VEHICLE BOARD

AFTER MOUNTING
TO TEST BOARD
(TOP X-RAY VIEW)

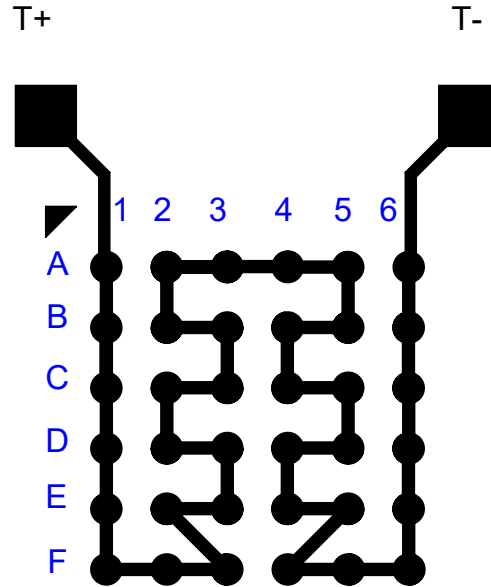

Notes:

- 1) PCB BOARD DIMENSIONS ARE PRESENTED ONLY AS A GUIDELINE. DESIGNERS SHOULD USE THEIR OWN EXPERIENCE WHEN DESIGNING PCB.
- 2) PCB Cu BALL PAD DIAMETER 0.56mm [22 MIL].
- 3) PCB DAISY CHAIN TRACING LINE WIDTH 0.20mm [8 MIL].
- 4) SMD (SOLDER MASK DEFINED) PAD OPENING 0.40mm [15.7 MIL].

TopLine®

TITLE			
BGA36T.8-DC069D DAISY CHAIN DUMMY			
SCALE	SIZE	DRAWING NO.	REV
	A	580699	A
DO NOT SCALE DRAWING			SHEET 2 OF 3

AC89@

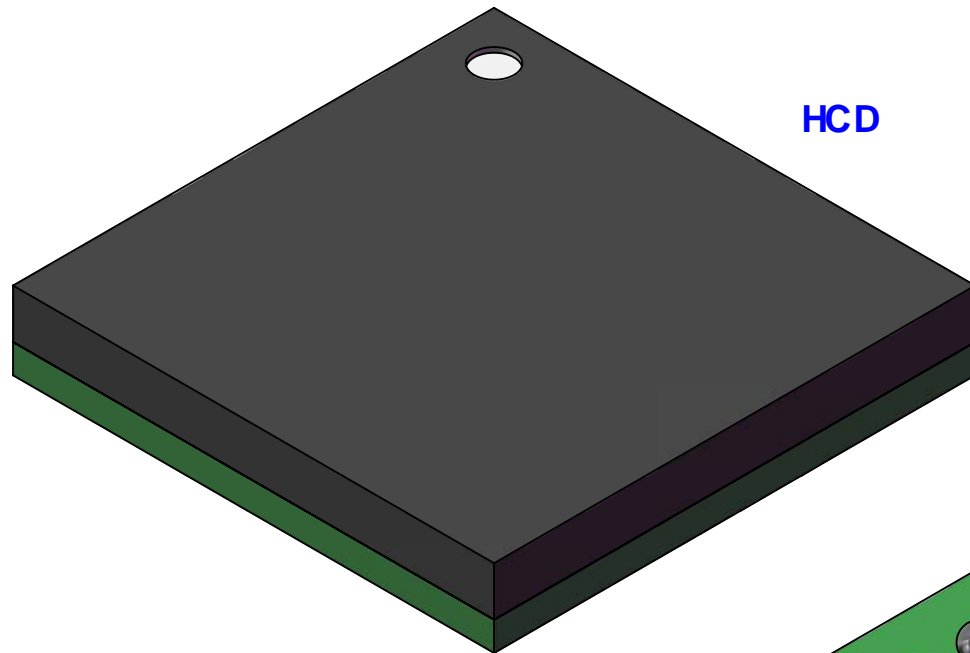

HCD

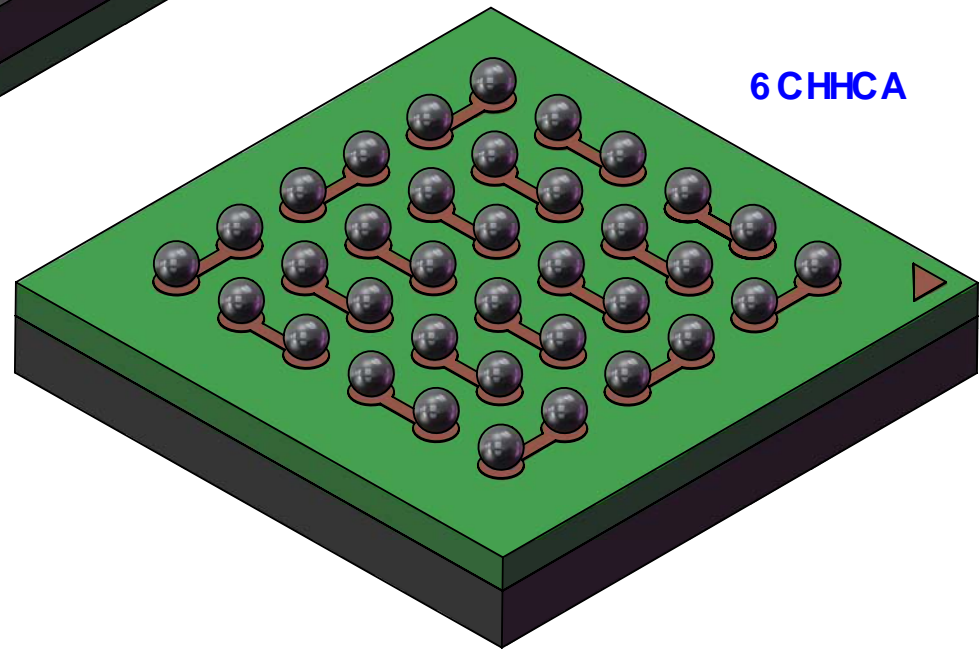

6 CHCA

TopLine®

TITLE BGA36T.8-DC069D
DAISY CHAIN DUMMY

SCALE	SIZE	DRAWING NO.	REV
	A	580699	A

DO NOT SCALE DRAWING

SHEET 3 OF 3